

Cash Management Solutions from Tidel

CashTrans is pleased to introduce the TACC (Time Access Cash Controller) from Tidel. This safe and cash dispenser is the standard for retailers since 1978.



The Industry-leading TACC provides a simple, user-friendly interface, easy-to-use cash dispensing, receipt drop operations, and high reliability all in a cost effective solution. The TACC minimizes everyday accounting burdens, allowing your managers and employees to spend more time with customers and less time managing money.

Applications

- Robbery Deterrent
- Internal Shrink Controls
- Retail Cash Control
- Safe Receipt Storage
- Cash Dispensing
- Replenish Cash for Register (POS)

Warranty

- 2 Year Parts and Labor (Inside the US)
- 1 Year Parts Only (Outside the US)



Tidel has grown into one of the largest manufacturers of cash management and security equipment in the world. Their success comes from one simple idea: they continue to pioneer products that are profitable for our customers. CashTrans is proud to be a partner!

Standard Features

- 1/4 Inch Powder Coated Steel Plate Body and Door
- Medeco Key Locks
- Internal Floor Anchors
- Dual Anti-Fish Drop Chutes to the Storage Vault
- Electronic Time-Delayed Change Fund Vending (Stores up to 88 Tubes)
- Alternate Vending Delay Time
- Integral Vend-Tube Locking Bar
- RoHS Lead-Free Compliant

Optional Features

- Armored Car Instant Access Key
- Custom Colors Available

Specifications:

| | |
|---------|---|
| Weight: | 290 lbs. (132 kg) |
| Height: | 30.75" (781 mm) |
| Width: | 21" (533 mm) |
| Depth: | 14.5" (368 mm) vault only 22" (559 mm) overall |

Power Requirements:

120 VAC 60Hz or 220 VAC 50Hz

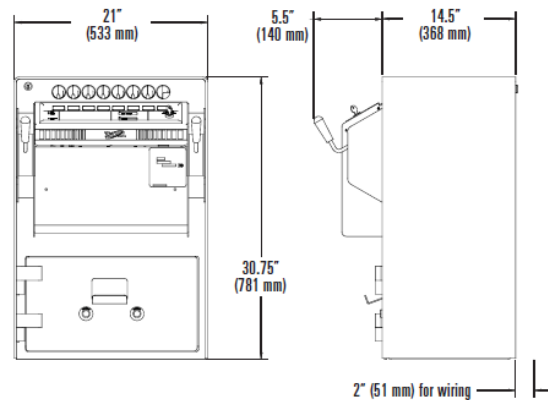

Since 1996, **CashTrans** has specialized in the deployment of cost efficient ATMs and have provided unparalleled processing services for independent financial institutions and small businesses. Our program consists of a complete full-service solution with both Help Desk and On-Sight Service and transaction processing. All equipment is serviced by Certified ATM Technicians strategically located to offer the fastest response time possible. **CashTrans** is committed to maintaining its leadership and to providing the latest technologies available in the industry today.

“We will earn your business everyday!”